

Red Oak Community School District

2011 North 8th Street

Red Oak, Iowa 51566

712.623.6600

www.redoakschooldistrict.com

Regular Board of Directors Meeting

Meeting Location: Sue Wagaman Board Room
Red Oak CSD Administrative Center
The Technology Building – Red Oak High School Campus

Monday, June 26, 2017 – 6:00 pm

- Amended Agenda –

1.0 Call to Order – Board of Directors Vice President Mark Johnson

2.0 Roll Call – Board of Directors Secretary Shirley Maxwell

3.0 Approval of the Agenda – Vice President Mark Johnson

4.0 Public Presenters/Guest and Visitors Addressing the Board

5.0 Communications

5.1 Good News from Red Oak Schools

5.2 Visitors and Presentations-

A- Bulinda Coates-United Group Insurance-Safety Group Insurance Program

B-Mindi Riibe-Taher, year-end presentation

5.3 Affirmations and Commendations

5.4 Correspondence

5.5 Public Comments

6.0 Consent Agenda

6.1 Review and Approval of Minutes from June 5, 2017, June 9, 2017 *pg 1-4*

6.2 Review and Approval of Monthly Business Reports *pg 5-22*

6.3 Open Enrollment Requests Consideration

6.3.A-Russell M Justice-Kindergartener from Griswold CSD to Red Oak CSD for 2017-2018 school year.

7.0 General Business for the Board of Directors

7.1 Old Business-none

7.2 New Business

7.2.1 Discussion/Approval of items to sell- busses, printers, Toro riding mower, etc. pg 23-24

7.2.2 Discussion/Approval of the purchase of riding lawn mower pg. 25-29

7.2.3 Change order from McKee Contracting Company in the amount of \$744.00 for blocking behind lockers and fold-up shower seat. pg 30-34

7.2.4 Discussion/Approval of membership on Labor Management Committee for staff handbooks.

7.2.5 Discussion/Approval of signs and hours on Middle School Cage area.

7.2.6 Discussion and Establishment of Salaries for 2017-2018 for Administrators:

7.2.6 A-Jeff Spotts, ROHS Principal

7.2.6 B-Nate Perrien, Middle School Principal

7.2.6 C-Gayle Allensworth, PK-5 Principal

7.2.7 Discussion and Establishment of Salaries for 2017-2018 for Directors

7.2.7 A-Bob Deter, Technology

7.2.7 B-Carlos Guerra, Transportation

7.2.7 C-Shirley Maxwell, School Business Official

7.2.8 Discussion and Establishment of Salaries for 2017-2018 for Heather Hall R.N., School Nurse; Linda Guerra, Interpreter Paraprofessional; District Administrative Center Staff Members, Deb Drey, Human Resource; Monica Blay, Accounting Clerk; and Kevin Herrick, Computer Hardware Technician; Karen Dean, Home School Assistant; Bonnie Viner, Home School Assistant, Chris Vannausdle, Maintenance Ground Tech; Adam Wenberg, Lead Maintenance

7.2.9 Discussion/Approval of service agreement with Woodward-Granger Community School District 2016-2017. pg 35

7.2.10 Personal Considerations

7.2.10 A-Resignation of Alan Spencer as Lead Teacher at High School effective June 30, 2017 pg 36

7.2.10 B-Resignation of Kelly Jones as Lead Teacher at Inman effective June 30th, 2017

7.2.10 C-Resignation of Deb Graber as Instructional Coach at Inman effective June 30th, 2017

7.2.10 D-Resignation of Larry Brian Orr from K-5 Student Support Coordinator effective at the end of the 2016-2017 school year. pg 37

7.2.10 E-Makaela Magneson-one year leave of absence as coach of 7th volleyball effective at the end of 2016-2017 year pg 38

7.2.10 F-Recommendation to hire Jerry Wallace as bus driver for the 2017-2018 school year pg 39

7.2.10 G- Recommendation to hire Tori Dolch as 3rd grade Teacher for the 2017-2018 school year pg 40

7.2.10 H-Recommendation to hire the following at Lead Teachers for 2017-2018 school year:

1. Tim Marsden-High School
2. Brett Eubank-High School
3. Mark Erickson-High School
4. Tracy Vannausdle-High School
4. Arryn Gillespie-Inman
5. Stephanie Berglund-Inman
6. Melinda Smits-Inman
7. Beth Rehbein-Inman
8. Deb Graber-Inman
9. Sonia Kunze-Washington
10. Michelle Cockburn-Washington
11. Mary Carlson-Middle School
12. Curt Adams-Middle School
12. Kelsey Mangold-Middle School

7.2.11 Board Evaluation of the Superintendent – Closed Session per Section 21.5(1)(i) of the Iowa Code to evaluate the professional competency of an individual whose appointment, hiring, performance or discharge is being considered when necessary to prevent needless and irreparable injury to that individual's reputation and that individual requests a closed session and per section 21.5(1)(a) of the Iowa Code to review or discuss records which are required or authorized by state or federal law to be kept confidential.

8.0 Reports

8.1 Administrative

8.2 Future Conferences, Workshops, Seminars

8.3 Other Announcements

9.0 Next Board of Directors Meeting: Monday, July 10, 2017 – 6:00 pm
Sue Wagaman Board Room
Red Oak CSD Administrative Center

10.0 Adjournment

Red Oak Community School District
Meeting of the Board of Directors
Meeting Location: Sue Wagaman Board Room, Red Oak CSD Administrative Center
Red Oak Technology Center, Red Oak High School Campus
June 5, 2017

This regular meeting of the Board of Directors of the Red Oak Community School District was called to order by Vice President Mark Johnson at 6:00 p.m.

Present:

Directors: Bryce Johnson, Kathy Walker, Mark Johnson, Bret Blackman
Paul Griffen and Bret Blackman joined the meeting electronically
Superintendent Tom Messinger, Business Manager Shirley Maxwell

Approval of Agenda

Motion by Director Bryce Johnson, second by Director Walker to approve the agenda with the order of agenda items at the discretion of the meeting chair. Motion carried unanimously.

Visitors and Presentations-Presentations:

Principal Spotts gave a presentation on High School Improvement.

Consent Agenda

Motion by Director Griffen, second by Director Walker to approve the consent agenda as presented. Motion carried unanimously.

- Review and Approval of Minutes from May 22, 2017
- Review and Approval of Monthly Business Reports

Old Business

Motion by Director Bryce Johnson, second by Director Griffen to approve the supplemental contracts for coaches and sponsors for the 2017-2018 school year as presented. Motion carried unanimously.

Motion by Director Blackman, second by Director Walker to approve the purchase of a propane Bluebird passenger school bus from School Bus Sales, Co. at the cost of \$99,570. Motion carried unanimously.

New Business

Motion by Director Bryce Johnson, second by Director Walker to approve the 2017-2018 Educational Services contracts with Southwestern Community College. Motion carried unanimously.

Motion by Director Walker, second by Director Bryce Johnson to approve the TAHER First Extension to Agreement for Food Service for the 2017-2018 school year. Motion carried unanimously.

Page 2 Continuation of June 5, 2017

Director Blackman joined the meeting in person at 7:03 p.m.

Motion by Director Walker, second by Director Griffen to approve the Administration re-assignment of duties for the 2017-2018 school year. Motion carried unanimously.

Personnel Considerations

Motion by Director Blackman, second by Director Walker to approve the resignation of Cole Darrow Middle School Girls Track Coach and Middle School 8th Grade Boys Basketball Coach effective at the end of 2016-2017 school year. Motion carried unanimously.

Motion by Director Blackman, second by Director Walker to approve the resignation of Dan Pollock- High School Assistant Boys Basketball Coach effective at the end of the 2016-2017 school year. Motion carried unanimously.

Motion by Director Blackman, second by Director Bryce Johnson to approve the resignation of Deb Blomstedt as Science Fair Coordinator effective June 1, 2017. Motion carried unanimously.

Motion by Director Blackman, second by Director Walker to approve the recommendation to hire Cole Darrow as High School Assistant Boys Track Coach effective for the 2017-2018 school year. Motion carried unanimously.

Motion by Director Blackman, second by Director Walker to approve the recommendation to hire Cole Darrow as High School Assistant Boys Basketball Coach for the 2017-2018 school year. Motion carried unanimously.

Motion by Director Blackman, second by Director Walker to approve the recommendation to hire Dan Pollock as Jr. High Boys Basketball Coach for the 2017-2018 school year. Motion carried unanimously.

Motion by Director Blackman, second by Director Walker to approve the recommendation to hire Barb Lombard as Football Cheer Sponsor for the 2017-2018 school year. Motion carried unanimously.

Motion by Director Blackman, second by Director Walker to approve the recommendation to hire Cheri McFarland as Wrestling Cheer Sponsor for the 2017-2018 school year. Motion carried unanimously.

Motion by Director Blackman, second by Director Walker to approve the recommendation to hire Kelli Schram as Middle School 7th-8th Math for the 2017-2018 school year. Motion carried unanimously.

Motion by Director Bryce Johnson, second by Director Walker to approve the recommendation to hire Brittan Sindt as Inman Kindergarten for the 2017-2018 school year. Motion carried unanimously.

Motion by Director Walker, second by Director Griffen to approve the recommendation to hire Brandi Blackman Inman 1st grade for the 2017-2018 school year. Ayes: Griffen, Walker, Mark Johnson, Bryce Johnson, Abstain: Blackman

Page 3 Continuation of June 5, 2017

Next Regular Board of Director's Meeting:

Regular Board Meeting
Monday, June 26, 2017 – 6:00 p.m.
Sue Wagaman Board Room
Red Oak CSD Administrative Center

Board Adjourns

Motion by Director Blackman, second by Director Walker to adjourn the meeting at 7:23 p.m.
Motion carried unanimously.

Mark Johnson, Vice President

Shirley Maxwell, Board Secretary

Red Oak Community School District
Special Meeting of the Board of Directors
Meeting Location: Sue Wagaman Board Room, Red Oak CSD Administrative Center
Red Oak Technology Center, Red Oak High School Campus
June 9, 2017

This special meeting of the Board of Directors of the Red Oak Community School District was called to order by President Paul Griffin at 12:00 p.m.

Present:

Directors: Kathy Walker

Supt. Tom Messinger

Joining Electronically: Paul Griffen, Mark Johnson, Bryce Johnson, Board Secretary Shirley Maxwell

Absent: Bret Blackman

Approval of Agenda

Motion by Director Walker, second by Director Bryce Johnson to approve the agenda as presented with the order of agenda items at the discretion of the board president. Motion carried unanimously.

Approval of Purchase of Compressor Replacement at Washington School

Motion by Director Walker, second by Director Mark Johnson to approve the bid from Ray Martin Company for the compressor replacement on the roof top unit at the Washington School. Motion carried unanimously. This special meeting and action was taken due to the lack of air conditioning in the building and the damage that could result if it was not repaired promptly.

Board Adjourns

Motion by Director Walker, second by Director Bryce Johnson to adjourn the meeting at 12:07 p.m. Motion carried unanimously.

Paul Griffen, President

Shirley Maxwell, Board Secretary

RED OAK BOARD REPORT

Unposted; Batch Description JUNE 26 BOARD MEETING<, CHECKS 2017

Vendor Name	Invoice Number	Amount
Account Number	Detail Description	Amount
Checking Account ID 1	Fund Number 10	OPERATING FUND
BATTEN SANITATION SERVICE	053117	3,695.00
10 0010 2600 000 0000 421	DISTRICT GARBAGE	3,695.00
Vendor Name BATTEN SANITATION SERVICE		<u>3,695.00</u>
BELT AND SONS, R.K.	75022	130.59
10 0020 2600 000 0000 433	INSPECTION & OIL	130.59
BELT AND SONS, R.K.	75023	146.91
10 0020 2600 000 0000 433	INSPECTION & OIL	146.91
BELT AND SONS, R.K.	75024	146.91
10 0020 2600 000 0000 433	#17 INSPECTION & OIL	146.91
BELT AND SONS, R.K.	75025	268.36
10 0020 2600 000 0000 433	#25 INSPECTION & BRAKE SHOES REPAIR	268.36
BELT AND SONS, R.K.	75026	85.00
10 0020 2600 000 0000 433	#15 INSPECTION	85.00
BELT AND SONS, R.K.	75027	488.09
10 0020 2600 000 0000 433	#20 INSPECTION & SWAY BAR REPAIR	488.09
BELT AND SONS, R.K.	75042	85.00
10 0020 2600 000 0000 433	#27 INSPECTION	85.00
Vendor Name BELT AND SONS, R.K.		<u>1,350.86</u>
BRUCE SUPPLIES & CONSTRUCTION INC.	954	80.00
10 0010 2600 000 0000 618	APRIL/MAY WASHES	80.00
Vendor Name BRUCE SUPPLIES & CONSTRUCTION INC.		<u>80.00</u>
BUS PARTS WAREHOUSE	77974	36.25
10 0020 2700 000 0000 618	Amber warning Light	25.25
10 0020 2700 000 0000 618	Shipping	15.26
10 0020 2700 000 0000 618	Credit for shipping	(4.26)
Vendor Name BUS PARTS WAREHOUSE		<u>36.25</u>
CAM COMMUNITY SCHOOL DISTRICT	060717	3,379.34
10 0010 1000 100 0000 567	OPEN ENROLLMENT-2ND SEMESTER	3,223.00
10 0010 1000 130 3116 567	TLC-2ND SEMESTER	156.34
Vendor Name CAM COMMUNITY SCHOOL DISTRICT		<u>3,379.34</u>
CASEY'S	053117	91.14
10 0020 2700 000 0000 626	MAY FUEL CHARGES	91.14
Vendor Name CASEY'S		<u>91.14</u>
CDW GOVERNMENT, INC.	1BR6L76	1,717.40
10 3230 1000 300 3261 652	Epson BrightLink 695Wi LCD projector	1,717.40
Vendor Name CDW GOVERNMENT, INC.		<u>1,717.40</u>
CENTURY LINK	060117	132.00
10 0020 2490 000 0000 530	TRANSMITTER LINE-2WAY RADIO	132.00
Vendor Name CENTURY LINK		<u>132.00</u>
CHEMSEARCH	2742569	278.00
10 0010 2600 000 0000 432	WATER TREATMENT PROGRAM	278.00
Vendor Name CHEMSEARCH		<u>278.00</u>

Vendor Name	Invoice Number	Amount
Account Number	Detail Description	Amount
COUNCIL BLUFFS COMM SCHOOLS	HFS05-5463	7,293.42
10 0010 1200 217 3303 561	TUITION-SPED 3-MAY JUNE	7,293.42
COUNCIL BLUFFS COMM SCHOOLS	PMIC-5463	11,285.00
10 0010 1000 420 1119 561	PMIC BILLING 2016-2017	11,285.00
Vendor Name COUNCIL BLUFFS COMM SCHOOLS		<u>18,578.42</u>

Account Number	Detail Description	Amount
COUNSEL OFFICE & DOCUMENTS	241857	3,073.10
10 1902 1000 100 0000 359	WASH OFFICE CLICKS	107.47
10 1902 1000 100 0000 359	WASH OFFICE LEASE	113.98
10 1902 1000 100 0000 359	WAS MEDIA LEASE	134.42
10 1902 1000 100 0000 359	WASH MEDIA CLICKS	166.74
10 3230 1000 100 0000 359	HS OFFICE CLICKS	112.11
10 3230 1000 100 0000 359	HS OFFICE LEASE	160.48
10 3230 1000 100 0000 359	HS MEDIA LEASE	134.38
10 3230 1000 100 0000 359	HS TECH CENTER CLICKS	4.08
10 3230 1000 100 0000 359	HS MEDIA CLICKS	253.34
10 2020 1000 100 0000 359	MS MEDIA CLICKS	95.02
10 2020 1000 100 0000 359	MS MEDIA LEASE	107.69
10 2020 1000 100 0000 359	MS OFFICE LEASE	139.00
10 2020 1000 100 0000 359	MS OFFICE CLICKS	160.99
10 2020 1000 100 0000 359	MS 3rd FLOOR CLICKS	5.14
10 1901 1000 100 0000 359	IPS LOUNGE CLICKS	93.67
10 1901 1000 100 0000 359	IPS LOUNGE LEASE	107.69
10 1901 1000 100 0000 359	IPS OFFICE LEASE	139.00
10 1901 1000 100 0000 359	IPS MEDIA LEASE	134.38
10 1901 1000 100 0000 359	IPS OFFICE CLICKS	137.86
10 1901 1000 100 0000 359	IPS MEDIA CLICKS	413.94
10 0020 2700 000 0000 359	TRANS COPIER CLICKS	0.91
10 0010 2520 000 0000 618	TECH CENTER LEASE	250.78
10 0010 2520 000 0000 618	TECH CENTER	87.04
10 0010 2235 000 0000 350	STEADYSERVE	12.99
Vendor Name COUNSEL OFFICE & DOCUMENTS		<u>3,073.10</u>

DEBOLT, BETH	061417	41.21
10 2020 1000 100 0000 580	MILEAGE REIMBURSEMENT DEC-JUNE	94.11
10 2020 1000 100 0000 580	OVERPAID FROM DEC	(52.90)
Vendor Name DEBOLT, BETH		<u>41.21</u>

DEMCO	6140217	230.96
10 1902 2222 000 0000 618	Reddi-Covers book covers, 8"	46.29
10 1902 2222 000 0000 618	Reddi-Covers book covers, 11"	46.59
10 1902 2222 000 0000 618	Reddi-Covers book covers, 12"	56.99
10 1902 2222 000 0000 618	Highsmith premium book tape, 3" x 180'	50.24
10 1902 2222 000 0000 618	Norbond Liquid Plastic Adhesive, 8 oz.	11.78
10 1902 2222 000 0000 618	Shipping charge	19.07
Vendor Name DEMCO		<u>230.96</u>

DENTLINGER, CONNIE	061417	199.09
10 1901 1000 100 8001 612	REIMBURSEMENT FOR CLASSROOM SUPPLIES	199.09

6

Vendor Name	Invoice Number	Amount
Account Number	Detail Description	Amount
Vendor Name DENTLINGER, CONNIE		199.09
DETER, BOB	060517	10.69
10 0010 2235 000 0000 618	DISPOSABLE GLOVES-MENARDS REIMBURSEMENT	10.69
Vendor Name DETER, BOB		10.69
DHS CASHIER 1ST FLOOR	10111906	36,544.47
10 0010 4634 219 4634	PROVIDERS SHARE-MAY MEDICARE	36,544.47
Vendor Name DHS CASHIER 1ST FLOOR		36,544.47
DOLCH, REBECCA	061617	73.78
10 1901 1000 100 8001 612	REIMBURSEMENT FOR CLASSROOM SUPPLIES	73.78
Vendor Name DOLCH, REBECCA		73.78
DRAKE UNIVERSITY	062017	900.00
10 0010 2213 132 3376 330	CHARACTER COUNTS/SCHOOL CLIMATEx9	900.00
Vendor Name DRAKE UNIVERSITY		900.00
EAST MILLS COMMUNITY SCHOOLS	062017	17,053.04
10 0010 1000 130 3116 567	2ND SEMESTER-TLC	938.04
10 0010 1000 100 0000 567	2ND SEMESTER-OPEN ENROLLMENT	16,115.00
Vendor Name EAST MILLS COMMUNITY SCHOOLS		17,053.04
ESSEX COMMUNITY SCHOOL DIST.	062217	13,673.70
10 0010 1000 100 0000 567	2ND SEMESTER OE	12,892.00
10 0010 1000 130 3116 567	2ND SEMESTER TLC	781.70
Vendor Name ESSEX COMMUNITY SCHOOL DIST.		13,673.70
FAREWAY FOOD STORES	00252737	58.70
10 0010 2310 000 0000 611	BOARD SUPPLIES	58.70
FAREWAY FOOD STORES	00356148	18.18
10 3230 1300 310 0000 612	Pork Loin	18.18
Vendor Name FAREWAY FOOD STORES		76.88
FIRST BANKCARD	051017	87.36
10 0010 2600 000 0000 618	3-INCH IRON C-CLAMP	87.36
FIRST BANKCARD	051017-01	129.79
10 0010 2600 000 0000 618	GROMMET PLIERS	129.79
FIRST BANKCARD	051617	150.74
10 3230 2222 000 0000 618	Office Impressions Clear Laminating Pouc	72.09
10 3230 2222 000 0000 618	Smead Manila 100 Precent Recycled File F	10.78
10 3230 2222 000 0000 618	Smead Heavy-Duty hanging File Folder Fra	23.28
10 3230 2222 000 0000 618	50 Shipping Mailers 4 1/8 x 9 1/2 White	14.00
10 3230 2222 000 0000 618	Sharpie Permanent Markers, Fine Point, B	8.97
10 3230 2222 000 0000 618	Westcott three Pack Value Pack Scissors,	6.26
10 3230 2222 000 0000 618	BIC White-Out EZ Correct Corrections tap	15.36

7

06/23/2017 09:23 AM

Unposted; Batch Description JUNE 26 BOARD MEETING<, CHECKS 2017

User ID: BLAYM

Vendor Name	Invoice Number	Amount	
Account Number	Detail Description		Amount
FIRST BANKCARD	051717	69.99	
10 0010 2600 000 0000 618	DOOR CLOSER FLUSH-KITCHEN FREEZER		69.99
FIRST BANKCARD	052517	94.20	
10 0010 1000 100 8203 612	PTO MANILLA CLASP ENVELOPES 6x100		94.20
FIRST BANKCARD	6033-77	64.92	
10 3230 1000 300 3261 652	Pliers-Grant		59.47
10 3230 1300 370 0000 612	Plliers		5.45
FIRST BANKCARD	81297934	28.95	
10 0010 2310 000 0000 611	EASEL'S FOR RETIREES		28.95
FIRST BANKCARD	84102358	291.20	
10 2020 1000 110 0000 580	DES MOINES MARRIOTT DOWNTOWN RESERVATION		291.20
FIRST BANKCARD	9000907749	385.00	
10 3230 2410 000 0000 618	NHS dues		385.00
Vendor Name FIRST BANKCARD			<u>1,302.15</u>
FOLLETT SCHOOL SOLUTIONS INC	629436A-2	219.53	
10 3230 2222 000 0000 643	63 Various YA Titles		219.53
FOLLETT SCHOOL SOLUTIONS INC	632575-4	52.16	
10 0010 1000 470 1118 641	Book: The Charmed Children of Rookskill		7.69
10 0010 1000 470 1118 641	Book: Full Cicada Moon		7.69
10 0010 1000 470 1118 641	Book: The Girl Who Drank the Moon		14.56
10 0010 1000 470 1118 641	Book: Hidden Figures		6.84
10 0010 1000 470 1118 641	Book: Paper Things		7.69
10 0010 1000 470 1118 641	Book: Stella by Starlight		7.69
Vendor Name FOLLETT SCHOOL SOLUTIONS INC			<u>271.69</u>
FREMONT MILLS COMMUNITY SCHOOL DISTRICT	0063	6,446.00	
10 0010 1000 100 0000 567	OPEN ENROLLMENT-2ND SEMESTER		6,446.00
Vendor Name FREMONT MILLS COMMUNITY SCHOOL DISTRICT			<u>6,446.00</u>
GILLESPIE, ARRYN	061617	149.38	
10 1901 1000 100 8001 612	REIMBURSEMENT FOR CLASSROOM SUPPLIES		149.38
Vendor Name GILLESPIE, ARRYN			<u>149.38</u>
GLENWOOD COMMUNITY SCHOOLS	060917	1,201.43	
10 0010 1200 217 3303 567	APEX BILLINGx3 ADMIN COSTS FY 17		1,201.43
GLENWOOD COMMUNITY SCHOOLS	060917-1	5,442.32	
10 0010 1200 217 3303 567	MAY APEX BILLING x2		5,442.32
Vendor Name GLENWOOD COMMUNITY SCHOOLS			<u>6,643.75</u>
GOODWILL INDUSTRIES, INC.	053117-13	924.00	
10 0010 1200 217 3303 320	WORK EXPERIENCE		924.00
GOODWILL INDUSTRIES, INC.	063017-02	84.00	
10 0010 1200 217 3303 320	WORK EXPERIENCE		84.00
Vendor Name GOODWILL INDUSTRIES, INC.			<u>1,008.00</u>
GRAVES, CJ	061617	50.00	
10 0010 1363 100 0000	DRIVERS ED REIMBURSEMENT		50.00

8

RED OAK BOARD REPORT

Unposted; Batch Description JUNE 26 BOARD MEETING<, CHECKS 2017

Vendor Name	Invoice Number	Amount
Account Number	Detail Description	Amount
Vendor Name GRAVES, CJ		50.00
GREEN HILLS AEA	34278	36.00
10 0010 1200 219 0000 612	36 18X24 POSTERS	36.00
GREEN HILLS AEA	34501	40.00
10 3230 2410 000 0000 618	4 BOXES ENVELOPES	40.00
Vendor Name GREEN HILLS AEA		76.00
GREEN TREE COMPANY, THE	5092	400.00
10 0010 2600 000 0000 432	2 LOADS OF DIRT	400.00
Vendor Name GREEN TREE COMPANY, THE		400.00
GRISWOLD COMMUNITY SCHOOLS	053017	27,032.64
10 0010 1000 100 0000 567	OPEN ENROLLMENT-2ND SEMESTER	25,784.00
10 0010 1000 130 3116 567	TLC-2ND SEMESTER	1,248.64
GRISWOLD COMMUNITY SCHOOLS	053117	303.19
10 3230 1000 100 0000 565	CONCURRENT ENROLLMENT 2016-2017	303.19
Vendor Name GRISWOLD COMMUNITY SCHOOLS		27,335.83
HARMSSEN, ANNA	061617	264.47
10 1901 1000 100 8001 612	REIMBURSEMENT FOR CLASSROOM SUPPLIES	264.47
Vendor Name HARMSSEN, ANNA		264.47
HOUGHTON STATE BANK	060717	15.00
10 0010 2310 000 0000 611	SAFE DEPOSIT BOX RENTAL	15.00
Vendor Name HOUGHTON STATE BANK		15.00
HY VEE FOOD STORES	051617	263.72
10 3230 2410 000 0000 618	Academic Breakfast	263.72
HY VEE FOOD STORES	051617-1	115.50
10 3230 2410 000 0000 618	Academic Breakfast	115.50
HY VEE FOOD STORES	052617	144.28
10 3230 1300 340 0000 612	groceries	86.28
10 3230 1300 340 0000 612	groceries	11.48
10 3230 1300 340 0000 612	groceries	18.31
10 3230 1300 340 0000 612	groceries	28.21
HY VEE FOOD STORES	055974	27.42
10 3230 1300 310 0000 612	Food Supplies for Class	27.42
HY VEE FOOD STORES	056142	31.06
10 1901 1920 100 1920 618	TREATS	31.06
HY VEE FOOD STORES	064984	49.99
10 1901 1920 100 1920 618	CAKE	49.99
HY VEE FOOD STORES	066159	26.59
10 1901 1000 100 8001 612	TREATS	26.59
HY VEE FOOD STORES	119115	12.96
10 1902 1000 100 8002 618	.96Ice Cream Bars for 5th grade's end-of	12.96
Vendor Name HY VEE FOOD STORES		671.52
IOWA COMMUNICATIONS NETWORK	504108	6.00
10 0010 2236 000 0000 536	ICN CHARGES MAY	6.00
Vendor Name IOWA COMMUNICATIONS NETWORK		6.00

Vendor Name	Invoice Number	Amount
Account Number	Detail Description	Amount
JOHNSON AUTO PARTS	6177-167320	45.32
10 0020 2700 000 0000 618	LAMP & REFLECTOR	45.32
JOHNSON AUTO PARTS	6177-167690	34.12
10 0020 2700 000 0000 618	LAMP & REFLECTORS	34.12
JOHNSON AUTO PARTS	6177-167880	23.92
10 0020 2700 000 0000 618	18 FLEX SUPPLY	23.92
JOHNSON AUTO PARTS	6177-167938	24.49
10 0020 2700 000 0000 618	HEADLIGHT LENS KIT	24.49
Vendor Name JOHNSON AUTO PARTS		<u>127.85</u>
JUICE PLUS COMPANY, THE	062317VOAGGR ANT	2,545.60
10 3230 1300 370 0000 612	TOWER GARDEN EXTRA	9.05
10 3230 1000 300 3261 652	TOWER GARDEN GRANT	2,536.55
Vendor Name JUICE PLUS COMPANY, THE		<u>2,545.60</u>
LEWIS CENTRAL COMMUNITY SCHOOL	060517	3,379.34
10 0010 1000 130 3116 567	TLC-2ND SEMESTER	156.34
10 0010 1000 100 0000 567	OPEN ENROLLMENT-2ND SEMESTER	3,223.00
Vendor Name LEWIS CENTRAL COMMUNITY SCHOOL		<u>3,379.34</u>
MEDIACOM	062117	1,680.00
10 0010 2236 000 0000 536	INTERNET	1,680.00
MEDIACOM	062117-01	714.83
10 0010 2236 000 0000 536	PRI LINES	714.83
Vendor Name MEDIACOM		<u>2,394.83</u>
MIDAMERICAN ENERGY	061217	322.70
10 1902 2600 000 0000 622	SPORTS COMPLEX ELECT	322.70
MIDAMERICAN ENERGY	061217-01	118.64
10 1912 2600 000 0000 622	WEBSTER ELECT	118.64
MIDAMERICAN ENERGY	061217-02	26,851.60
10 1901 2600 000 0000 622	IPS ELECT	6,036.78
10 1902 2600 000 0000 622	WASH ELECT	2,372.83
10 2020 2600 000 0000 622	BBALL COURT-ELECT	32.13
10 2020 2600 000 0000 622	MS ELECT	3,909.50
10 3230 2600 000 0000 622	TECH ELECT	14,161.24
10 0030 2600 000 0000 621	GAS FBALL FIELD	14.26
10 0030 2600 000 0000 622	ELECT FBALL FIELD	14.28
10 0020 2600 000 0000 622	BUS BARN ELECT	272.03
10 0020 2600 000 0000 621	BUS BARN GAS	38.55
Vendor Name MIDAMERICAN ENERGY		<u>27,292.94</u>
MILLS-MONTGOMERY CO CATTLEMENS ASSN	277	245.00
10 0010 1000 100 8203 612	CARNIVAL GRILLING	245.00
Vendor Name MILLS-MONTGOMERY CO CATTLEMENS ASSN		<u>245.00</u>
MOSS EDUCATIONAL & INDUSTRIAL TRAINING SOLUTIONS	3436	2,402.13
10 3230 1000 300 3261 652	3D Printer	2,002.14
10 3230 1000 300 3261 652	ABS Filament	399.99
Vendor Name MOSS EDUCATIONAL & INDUSTRIAL TRAINING SOLUTIONS		<u>2,402.13</u>
O'NEAL ELECTRIC CO. CONTRACTOR	5200-6301	220.00

Vendor Name	Invoice Number	Amount
Account Number	Detail Description	Amount
10 0010 2600 000 0000 432	VFD-IPS TEMP REPAIR	220.00
Vendor Name	O'NEAL ELECTRIC CO. CONTRACTOR	<u>220.00</u>
OREILLY AUTO PARTS	0298-425819	3.99
10 0020 2700 000 0000 618	REFLECTOR	3.99
Vendor Name	OREILLY AUTO PARTS	<u>3.99</u>
PIONEER MANUFACTURING CO	639261	1,180.00
10 0010 2600 000 0000 618	FIELDPAINT-BB & FB	1,180.00
Vendor Name	PIONEER MANUFACTURING CO	<u>1,180.00</u>
PRINCIPAL FINANCIAL GROUP	062317	59.04
10 0010 1000 100 8018 270	JULY DENTAL	59.04
Vendor Name	PRINCIPAL FINANCIAL GROUP	<u>59.04</u>
R & R PLUMBING	10186	436.78
10 0010 2600 000 0000 432	MS REPLACED TOILET	436.78
Vendor Name	R & R PLUMBING	<u>436.78</u>
RAY MARTIN COMPANY	7302	1,118.81
10 0010 2600 000 0000 432	WASH HOT WATER PUMP REPAIR	1,118.81
Vendor Name	RAY MARTIN COMPANY	<u>1,118.81</u>
RED OAK COMMUNITY SCHOOL DIST	062117	100.00
10 0010 1000 100 8203 612	PTO ADDITIONAL INSURANCE-2016-2017	100.00
Vendor Name	RED OAK COMMUNITY SCHOOL DIST	<u>100.00</u>
RED OAK EXPRESS	053117	388.74
10 0010 2572 000 0000 540	LEGALS-BOARD MEETING	388.74
Vendor Name	RED OAK EXPRESS	<u>388.74</u>
RED OAK GLASS	13416	450.47
10 0020 2600 000 0000 433	VAN WINDSHIELD REPAIR	450.47
RED OAK GLASS	13430	44.95
10 0020 2600 000 0000 433	ROCK CHIP REPAIR	44.95
RED OAK GLASS	13460	313.75
10 0020 2700 000 0000 434	BUS #5 WINDOR DOOR	313.75
Vendor Name	RED OAK GLASS	<u>809.17</u>
REHBEIN, BETH	060717	151.51
10 1901 1000 100 8001 612	REIMURSEMENT FOR CLASSROOM SUPPLIES	151.51
Vendor Name	REHBEIN, BETH	<u>151.51</u>
RIEMAN MUSIC, INC.	2521631	84.00
10 3230 2600 910 6220 433	Bari Sax (#015451) body repair and align	84.00
Vendor Name	RIEMAN MUSIC, INC.	<u>84.00</u>
SELLERS PEST CONTROL-ART SELLERS	24505	120.00
10 0010 2600 000 0000 425	DISTRICT WIDE PEST CONTROL	120.00
Vendor Name	SELLERS PEST CONTROL-ART SELLERS	<u>120.00</u>

06/23/2017 09:23 AM

Unposted; Batch Description JUNE 26 BOARD MEETING<, CHECKS 2017

User ID: BLAYM

Vendor Name	Invoice Number	Amount
Account Number	Detail Description	Amount
SIOUX CITY COMMUNITY SCH DIST	053017	73.24
10 0010 1000 420 1119 561	AT RISK RECOVERY CENTER	73.24
Vendor Name SIOUX CITY COMMUNITY SCH DIST		<u>73.24</u>
SOCS/FES	008180	405.00
10 0010 2236 000 0000 536	JUNE WEB HOSTING	405.00
Vendor Name SOCS/FES		<u>405.00</u>
SOUTHWESTERN COMMUNITY COLLEGE	32431	100.00
10 0020 2700 000 0000 340	12 HR NEW BUS DRIVER TRAINING--JW	100.00
Vendor Name SOUTHWESTERN COMMUNITY COLLEGE		<u>100.00</u>
STANTON COMMUNITY SCHOOL DIST.	061517	20,760.83
10 1902 2120 000 0000 591	SHARED GUIDANCE POSITION & TRAVEL	20,760.83
Vendor Name STANTON COMMUNITY SCHOOL DIST.		<u>20,760.83</u>
STERLING COMPUTERS	0024523	3,600.00
10 0010 2235 000 0000 618	Lenovo Yoga 11e Frames	3,600.00
Vendor Name STERLING COMPUTERS		<u>3,600.00</u>
SUPPLY WORKS	403350325	829.95
10 0010 2600 000 0000 618	38x60 PAPER TOWELS	829.95
Vendor Name SUPPLY WORKS		<u>829.95</u>
SW IA TIRE & SERVICE	71491	43.50
10 0020 2600 000 0000 433	TIRE REPAIR	43.50
SW IA TIRE & SERVICE	71693	19.16
10 0010 2600 000 0000 432	TUBE INSTALLED	19.16
SW IA TIRE & SERVICE	72473	391.08
10 0020 2700 000 0000 672	TIRESx3	391.08
Vendor Name SW IA TIRE & SERVICE		<u>453.74</u>
UNITED FARMERS COOPERATIVE	0292699	17.96
10 0010 2600 000 0000 618	TENNIS COURTS 100 PC SUPPLIES	17.96
UNITED FARMERS COOPERATIVE	0292781	4.47
10 0010 2600 000 0000 618	TENNIS KEY	4.47
UNITED FARMERS COOPERATIVE	0292807	119.92
10 0010 2600 000 0000 618	HS ASPHALT PATCH	119.92
UNITED FARMERS COOPERATIVE	0293166	10.99
10 0010 2600 000 0000 618	BBALL PREP	10.99
UNITED FARMERS COOPERATIVE	0293390	39.05
10 0010 2600 000 0000 618	BBALL FIELD PREP	39.05
UNITED FARMERS COOPERATIVE	0293396	3.29
10 0010 2600 000 0000 618	HS LIGHTER	3.29
UNITED FARMERS COOPERATIVE	0293422	35.65
10 0010 2600 000 0000 618	HS PLATFORM REPAIR SUPPLIES	35.65
UNITED FARMERS COOPERATIVE	0293801	18.12
10 0010 2600 000 0000 618	HS PLATFORM REPAIR SUPPLIES	18.12
UNITED FARMERS COOPERATIVE	0293828	1.76
10 0010 2600 000 0000 618	HS PLATFORM REPAIR SUPPLIES	1.76
UNITED FARMERS COOPERATIVE	0294074	179.88

12

06/23/2017 09:23 AM

Unposted; Batch Description JUNE 26 BOARD MEETING<, CHECKS 2017

User ID: BLAYM

Vendor Name	Invoice Number	Amount
Account Number	Detail Description	Amount
10 0010 2600 000 0000 618	HS ASPHALT	179.88
UNITED FARMERS COOPERATIVE	0294126	4.95
10 0010 2600 000 0000 618	TECH CENTER-ROOF PATCH SUPPLIES	4.95
UNITED FARMERS COOPERATIVE	0294203	31.78
10 0010 2600 000 0000 618	BBALL WINDSCREENS SUPPLIES	31.78
UNITED FARMERS COOPERATIVE	0294245	9.75
10 0010 2600 000 0000 618	SUPPLIES TO REPAIR CARGO TRAILER	9.75
UNITED FARMERS COOPERATIVE	0294501	35.78
10 0010 2600 000 0000 618	BBALL WINDSCREEN SUPPLIES	35.78
UNITED FARMERS COOPERATIVE	053117	4,751.54
10 0020 2700 000 0000 626	GAS	653.69
10 0020 2700 000 0000 627	DIESEL	1,406.01
10 0020 2700 000 0000 627	DIESEL-BOBCAT	24.81
10 0010 2700 217 3303 626	SPED MILEAGE FUEL	700.00
10 0010 2700 217 3303 627	SPED #10 DIESEL	67.46
10 0020 2700 000 0000 628	PROPANE	1,280.90
10 0020 2700 000 0000 628	PROPANE TAX	618.67
Vendor Name UNITED FARMERS COOPERATIVE		<u>5,264.89</u>

WALFORD, KIMBERLY	061617	62.65
10 1901 1000 100 8001 612	REIMBURSEMENT FOR CLASSROOM SUPPLIES	62.65
Vendor Name WALFORD, KIMBERLY		<u>62.65</u>

WARD'S SCIENCE	8048710930	1,580.95
10 3230 1300 310 0000 612	Classroom Supplies	1,580.95
WARD'S SCIENCE	8048710931	11.38
10 3230 1300 310 0000 612	Classroom Supplies	11.38
WARD'S SCIENCE	8048710932	19.00
10 3230 1300 310 0000 612	Classroom Supplies	19.00
WARD'S SCIENCE	8048721455	106.75
10 3230 1300 310 0000 612	Classroom Supplies	106.75
WARD'S SCIENCE	8048786721	189.90
10 3230 1300 310 0000 612	Classroom Supplies	189.90
WARD'S SCIENCE	8048860436	17.07
10 3230 1300 310 0000 612	Classroom Supplies	17.07
Vendor Name WARD'S SCIENCE		<u>1,925.05</u>

Fund Number 10		<u>222,390.20</u>
Checking Account ID 1	Fund Number 36	PHYSICAL PLANT & EQUIPMENT
BOYD JONES CONSTRUCTION COMPANY	15-007-09	11,621.19
36 2020 4700 000 0000 450	ADA PROJECT-15-007	11,621.19
Vendor Name BOYD JONES CONSTRUCTION COMPANY		<u>11,621.19</u>

CAMBLIN MECHANICAL INC	012017-02	2,111.78
36 2020 4700 000 0000 450	ADA PROJECT	2,111.78
CAMBLIN MECHANICAL INC	16-0044-003	848.77
36 2020 4700 000 0000 450	ADA PROJECT	848.77
Vendor Name CAMBLIN MECHANICAL INC		<u>2,960.55</u>

COUNCIL BLUFFS COMM SCHOOLS	HFS05-5463	1,014.42
36 0010 2600 000 0000 441	RENT-MAY JUNE	1,014.42
Vendor Name COUNCIL BLUFFS COMM SCHOOLS		<u>1,014.42</u>

RED OAK BOARD REPORT

Unposted; Batch Description JUNE 26 BOARD MEETING<, CHECKS 2017

Vendor Name	Invoice Number	Amount
Account Number	Detail Description	Amount
MCKEE CONTRACTING CO.	101316-04	4,394.24
36 2020 4700 000 0000 450	ADA PROJECT	4,394.24
MCKEE CONTRACTING CO.	10132016-03	12,791.54
36 2020 4700 000 0000 450	ADA PROJECT	12,791.54
Vendor Name MCKEE CONTRACTING CO.		<u>17,185.78</u>
O'NEAL ELECTRIC CO. CONTRACTOR	062017	680.90
36 2020 4700 000 0000 450	IPS ADA PROJECT	680.90
O'NEAL ELECTRIC CO. CONTRACTOR	062017-01	12,937.10
36 2020 4700 000 0000 450	ROCS D ADA UPDATE #1	12,937.10
Vendor Name O'NEAL ELECTRIC CO. CONTRACTOR		<u>13,618.00</u>
RIVERSIDE TECHNOLOGIES, INC	0162220	9,397.76
36 2020 2235 000 0000 739	HP DL380 Gen9 8SFF CTO Server	9,397.76
RIVERSIDE TECHNOLOGIES, INC	0162221	21,719.24
36 3900 2235 000 0000 739	HP DL380 Gen9 8SFF CTO Server	21,719.24
RIVERSIDE TECHNOLOGIES, INC	0166147	3,500.00
36 0010 2235 000 0000 350	RTI_Install_Svcs	3,500.00
Vendor Name RIVERSIDE TECHNOLOGIES, INC		<u>34,617.00</u>
TREBRON COMPANY INC	062317	10,515.00
36 3900 2235 000 0000 739	Sophos WS5000 Web Appliance w/3 yr. Warr	10,515.00
Vendor Name TREBRON COMPANY INC		<u>10,515.00</u>
Fund Number 36		<u>91,531.94</u>
Checking Account ID 1		<u>313,922.14</u>
Checking Account ID 2	Fund Number 61	SCHOOL NUTRITION FUND
UNITED FARMERS COOPERATIVE	053117	66.00
61 0010 2650 000 0000 626	LUNCH VAN FUEL	66.00
Vendor Name UNITED FARMERS COOPERATIVE		<u>66.00</u>
Fund Number 61		<u>66.00</u>
Checking Account ID 2		<u>66.00</u>
Checking Account ID 3	Fund Number 21	STUDENT ACTIVITY FUND
ABRAHAM LINCOLN SCHOOL	062017	90.00
21 0010 1400 920 6835 320	TOURNEY ENTRY FEE	90.00
Vendor Name ABRAHAM LINCOLN SCHOOL		<u>90.00</u>
ADVENTURELAND	0081175	1,225.00
21 2020 1400 910 6220 618	COST FOR 7/8 BAND TO ATTEND ADVERTURELAN	1,225.00
Vendor Name ADVENTURELAND		<u>1,225.00</u>
ASPI SOLUTIONS, INC	10628	342.00
21 0010 1400 920 6840 340	ONLINE REGISTRATION FOR MEETS	96.00
21 0010 1400 920 6840 340	ONLINE REGISTRATION FOR MEETS	48.00
21 0010 1400 920 6740 320	ONLINE REGISTRATION FOR MEETS	60.00
21 0010 1400 920 6740 320	ONLINE REGISTRATION FOR	90.00

14

06/23/2017 09:23 AM

Unposted; Batch Description JUNE 26 BOARD MEETING<, CHECKS 2017

User ID: BLAYM

Vendor Name	Invoice Number	Amount
Account Number	Detail Description	Amount
21 0010 1400 920 6740 320	MEETS ONLINE REGISTRATION FOR MEETS	48.00
Vendor Name ASPI SOLUTIONS, INC		<u>342.00</u>
ATLANTIC HIGH SCHOOL	052217	100.00
21 0010 1400 920 6835 320	SOFTBALL TOURNEY ENTRY FEE	100.00
Vendor Name ATLANTIC HIGH SCHOOL		<u>100.00</u>
BACUS, JOHN	061617	125.00
21 0010 1400 920 6730 320	JV/V BB OFFICIAL	125.00
Vendor Name BACUS, JOHN		<u>125.00</u>
BEWLEY, JAMES	061917	125.00
21 0010 1400 920 6835 320	SB DH OFFICAL	125.00
Vendor Name BEWLEY, JAMES		<u>125.00</u>
BOULDERS INN & SUITES POLK CITY	053117	520.00
21 0010 1400 920 6840 580	STATE TRACK ROOMS	520.00
Vendor Name BOULDERS INN & SUITES POLK CITY		<u>520.00</u>
BRUNSTING, ROD	061917	125.00
21 0010 1400 920 6730 320	DB BB OFFICIAL	125.00
Vendor Name BRUNSTING, ROD		<u>125.00</u>
DANIELS, MATT	061517	75.00
21 0010 1400 920 6730 320	JV/ V BBALL RAINOUT	75.00
Vendor Name DANIELS, MATT		<u>75.00</u>
DOYLE, JIM	060717	110.00
21 0010 1400 920 6835 320	JV/V SB OFFICIAL	110.00
Vendor Name DOYLE, JIM		<u>110.00</u>
FAREWAY FOOD STORES	00245936	162.03
21 3230 1400 950 7407 618	SUPPLIES FOR 1ST GRADE ACRES DAY	162.03
Vendor Name FAREWAY FOOD STORES		<u>162.03</u>
FIRST BANKCARD	051917	520.23
21 2020 1400 910 6220 618	ORDER FROM CUSTOM INK FOR MIDDLE SCHOOL	477.94
21 2020 1400 910 6220 618	RUSH SHIPPING TO GET BY MAY 25.	47.29
21 2020 1400 910 6220 618	COUPON	(5.00)
FIRST BANKCARD	10339	75.00
21 0010 1400 920 6730 618	QUIKSTATS IMPORT FOR BASEBALL STATS	75.00
Vendor Name FIRST BANKCARD		<u>595.23</u>
FREED, WAYNE	060617	110.00
21 0010 1400 920 6835 320	JV/V SB OFFICIAL	110.00
Vendor Name FREED, WAYNE		<u>110.00</u>
GRADOVILLE, RONALD	061517	75.00

15

06/23/2017 09:23 AM

Unposted; Batch Description JUNE 26 BOARD MEETING<, CHECKS 2017

User ID: BLAYM

Vendor Name	Invoice Number	Amount
Account Number	Detail Description	Amount
21 0010 1400 920 6730 320	JV/V BB OFFICIAL RAINOUT	75.00
Vendor Name GRADOVILLE, RONALD		<u>75.00</u>
HOOGESTRAAT, JD	060617	110.00
21 0010 1400 920 6835 320	JV/V SB OFFICIAL	110.00
Vendor Name HOOGESTRAAT, JD		<u>110.00</u>
HOWARD'S SPORTING GOODS	05282-00	105.88
21 0010 1400 920 6600 618	FIELD PENNANTS	105.88
Vendor Name HOWARD'S SPORTING GOODS		<u>105.88</u>
HY VEE FOOD STORES	051717	96.79
21 0010 1400 920 6600 618	COOKIES FOR SENIOR AWARDS	96.79
HY VEE FOOD STORES	051717-1	5.99
21 0010 1400 920 6600 618	GATORADE FOR BALLOON WEIGHTS	5.99
HY VEE FOOD STORES	052417	105.50
21 0010 1400 920 6600 618	BALLOONS FOR PEP RALLY	35.00
21 0010 1400 920 6600 618	BALLOONS FOR SENIOR AWARDS NIGHT	18.00
21 0010 1400 920 6600 618	WEIGHTS FOR BALLOONS	2.50
21 0010 1400 920 6600 618	FLORAL ARRANGEMENT	50.00
HY VEE FOOD STORES	065584	115.96
21 2020 1400 950 7421 618	VARIOUS ITEMS FOR CONCESSIONS AT THE END	115.96
Vendor Name HY VEE FOOD STORES		<u>324.24</u>
JAMES, DANIEL	060617	125.00
21 0010 1400 920 6730 320	JV/V BB OFFICIAL	125.00
Vendor Name JAMES, DANIEL		<u>125.00</u>
JAMES, MIKE	060617	125.00
21 0010 1400 920 6730 320	JV/V BB OFFICIAL	125.00
JAMES, MIKE	061917	125.00
21 0010 1400 920 6730 320	DH BB OFFICIAL	125.00
Vendor Name JAMES, MIKE		<u>250.00</u>
JENSEN, KENT	060817	125.00
21 0010 1400 920 6730 320	JV/V BB OFFICIAL	125.00
Vendor Name JENSEN, KENT		<u>125.00</u>
KUDRON, PHIL	061217	125.00
21 0010 1400 920 6835 320	SB JV/VAR OFFICIAL	125.00
Vendor Name KUDRON, PHIL		<u>125.00</u>
LARSEN, JAMES	061217	125.00
21 0010 1400 920 6730 320	JV/V BB OFFICIAL	125.00
Vendor Name LARSEN, JAMES		<u>125.00</u>
LARSON, MARK	060817	130.00
21 0010 1400 920 6835 320	VAR DH OFFICIAL	130.00
LARSON, MARK	061517	75.00
21 0010 1400 920 6835 320	SB DH OFFICIAL RAINOUT	75.00
Vendor Name LARSON, MARK		<u>205.00</u>

16

06/23/2017 09:23 AM

Unposted; Batch Description JUNE 26 BOARD MEETING<, CHECKS 2017

User ID: BLAYM

Vendor Name	Invoice Number	Amount
Account Number	Detail Description	Amount
MODERN SOUND ENGINEERING	11805	4,842.32
21 0010 1400 920 6730 739	SOUND SYSTEM FOR BASEBALL FIELD	4,842.32
Vendor Name	MODERN SOUND ENGINEERING	<u>4,842.32</u>
RED OAK GREENHOUSES	94037	198.00
21 3230 1400 950 7421 618	SUPPLIES FOR FLOWER SALE FUNDRAISER	198.00
Vendor Name	RED OAK GREENHOUSES	<u>198.00</u>
RED OAK SCHOOL SCHOLARSHIP ACCOUNT	062017	200.00
21 3230 1400 950 7479 618	LETTERMEN'S DARNETTE HARMON SCHOLARSHIP	200.00
Vendor Name	RED OAK SCHOOL SCHOLARSHIP ACCOUNT	<u>200.00</u>
SAUNDERS, BRUCE	061917	125.00
21 0010 1400 920 6835 320	SB DH OFFICIAL	125.00
Vendor Name	SAUNDERS, BRUCE	<u>125.00</u>
SMITH WALBRIDGE BAND PRODUCTS	061917	249.39
21 3230 1400 910 6220 618	COLOR GUARD FLAGS AND POLES	249.39
Vendor Name	SMITH WALBRIDGE BAND PRODUCTS	<u>249.39</u>
SPORTS GRAPHICS	27279	2,017.00
21 0010 1400 920 6730 618	1ST BASE LINE WINDSCREEN	624.00
21 0010 1400 920 6730 618	3RD BASE LINE WINDSCREEN 3'3" X 80'21 00	285.00
21 0010 1400 920 6730 618	3RD BASE LINE WINDSCREEN 5'3" X 85'	294.00
21 0010 1400 920 6730 618	3RD BASE LINE WINDSCREEN 5'3" X 11'6"	84.00
21 0010 1400 920 6730 618	3RD BASE LINE WINDSCREEN 5'3" X 5'2"	21.00
21 0010 1400 920 6730 618	BULLPEN WINDSCREEN 5'3" X 79'9"	285.00
21 0010 1400 920 6730 618	BULLPEN WINDSCREEN 5'3" X 29'5"	104.00
21 0010 1400 920 6730 618	BULLPEN WINDSCREEN 7'3" X 15'10"	90.00
21 0010 1400 920 6730 618	BULLPEN WINDSCREEN 7'3" X 7'1"	495.00
21 0010 1400 920 6730 618	SHIPPING AND HANDLING	185.00
21 0010 1400 920 6730 618	DISCOUNT	(450.00)
SPORTS GRAPHICS	27280	1,947.00
21 0010 1400 920 6650 618	SHIPPING AND HANDLING	95.00
21 0010 1400 920 6650 618	WINDSCREEN FOR HS TENNIS COURTS.	1,852.00
Vendor Name	SPORTS GRAPHICS	<u>3,964.00</u>
STUMPS	904048	154.10
21 3230 1400 950 7413 618	SUPPLIES FOR PROM	154.10
Vendor Name	STUMPS	<u>154.10</u>
TAYLOR, DUSTIN	060817	125.00
21 0010 1400 920 6730 320	JV/V BB OFFICIAL	125.00
Vendor Name	TAYLOR, DUSTIN	<u>125.00</u>

17

06/23/2017 09:23 AM

Unposted; Batch Description JUNE 26 BOARD MEETING<, CHECKS 2017

User ID: BLAYM

Vendor Name	Invoice Number	Amount
Account Number	Detail Description	Amount
THOLEN, MARK	061517	75.00
21 0010 1400 920 6835 320	SB DH OFFICIAL RAINOUT	75.00
Vendor Name THOLEN, MARK		<u>75.00</u>
TLUSTOS, BOB	060817	130.00
21 0010 1400 920 6835 320	VAR DH SB OFFICIAL	130.00
Vendor Name TLUSTOS, BOB		<u>130.00</u>
VARSIITY SPIRIT FASHION	74602401	192.90
21 3230 1400 950 7459 618	MALE CHEER UNIFORM	192.90
Vendor Name VARSITY SPIRIT FASHION		<u>192.90</u>
VOSS, RORY	061217	125.00
21 0010 1400 920 6730 320	JV VAR BB OFFICIAL	125.00
VOSS, RORY	061617	125.00
21 0010 1400 920 6730 320	JV/V BB OFFICIAL	125.00
Vendor Name VOSS, RORY		<u>250.00</u>
WAX, GARY	060717	110.00
21 0010 1400 920 6835 320	JV/V SB OFFICIAL	110.00
Vendor Name WAX, GARY		<u>110.00</u>
WIEGEL, SHANE	061217	125.00
21 0010 1400 920 6835 320	SB JV/V OFFICIAL	125.00
Vendor Name WIEGEL, SHANE		<u>125.00</u>
Fund Number 21		<u>16,015.09</u>
Checking Account ID 3		<u>16,015.09</u>

18

JUNE PREPAID CHECKS

	A	B	C	D	E	F
	CHECK #	CHECK ISSUED TO	ITEMS PURCHASED	CHECK AMT	DATE APPROVED	APPROVED BY
1						
2	17100	TOTAL FUNDS BY HASLER	POSTAGE FILL	\$1,000.00	6/12/2017	*****
3	170999	AP EXAMINATIONS	AP EXAMS	\$406.00	6/12/2017	*****
4						
5						
6						
7						
8						
9						
10						
11						
12						
13						
14						
15						
16						
17						
18						
19						
20						
21						
22						
23						
24						

	GENERAL FUND	MANAGEMENT	PHYSICAL PLANT AND EQUIPMENT	LEVY	DEBT SERVICE	SAVE TAXES
Beg. Balance 05-01-2017	\$3,744,548.09	\$2,371,451.73	\$1,018,648.34	\$528,230.14	\$3,161,220.60	
Revenue	\$906,051.41	\$17,627.93	\$22,797.98	\$20,831.13	\$231,617.01	
Expenditure	\$952,463.62	\$0.00	\$59,359.10	\$527,180.00	\$0.00	
Balance 05-31-2017	\$3,698,135.88	\$2,389,079.66	\$982,087.22	\$21,881.27	\$3,392,837.61	
Balance 05-31-2016	\$4,002,145.38	\$2,256,656.01	\$914,580.33	\$7,616.76	\$3,830,976.90	
		\$10,484,021.64	\$10,484,021.64			
Checking Account .2%	Checking Account					
	ISJIT	\$9.65				
	Outstanding Checks	\$17,453.00				
	Transfer fr Gen. Fund					
	to Activity	\$209.69				
		\$10,484,021.64				
Beg. Balance 05-01-2017	ACTIVITY FUND		NUTRITION FUND			
Revenue	\$190,952.70		\$138,569.34			
Expenditure	\$21,939.33		\$55,539.80			
Balance 05-31-2017	\$16,627.95		\$50,055.88			
Balance 05-31-2016	\$196,264.08		\$144,053.26			
	\$189,284.15		\$149,137.25			
Checking Account .20%						
ISJIT	\$199,155.18		\$139,284.69			
Outstanding cks	\$3,100.79		\$4,772.27			
Book Balance	\$196,054.39		\$3.70			
Transfer from general fund	209.69		\$144,053.26			
	\$196,264.08					

PHYSICAL PLANT AND EQUIPMENT LEVY

2014-2015
Beginning Balance (July 1) \$172,761.89

Add: Revenue	Property Taxes	EMC Insurance	MS Water Damage	Slight Damage (Storm)	Refund of Prior Year Expenditure	Subtotal
	\$112,014.21	\$24,186.75	\$141,283.71	\$109,081.00	\$905,375.68	\$978,137.57
	Property Taxes	EMC Insurance	MS Water Damage	Slight Damage (Storm)	Refund of Prior Year Expenditure	Subtotal
	\$112,014.21	\$24,186.75	\$141,283.71	\$109,081.00	\$905,375.68	\$978,137.57

2014-2015
Beginning Balance (July 1) \$92,414.16

Add: Revenue	Property Taxes	EMC Insurance	MS Water Damage	Slight Damage (Storm)	Refund of Prior Year Expenditure	Subtotal
	\$113,902.63	\$405,020.88	\$482,871.98	\$4,292.46	\$16,404.76	\$989,690.48
	Property Taxes <td>EMC Insurance <td>MS Water Damage <td>Slight Damage (Storm) <td>Refund of Prior Year Expenditure <td>Subtotal</td> </td></td></td></td>	EMC Insurance <td>MS Water Damage <td>Slight Damage (Storm) <td>Refund of Prior Year Expenditure <td>Subtotal</td> </td></td></td>	MS Water Damage <td>Slight Damage (Storm) <td>Refund of Prior Year Expenditure <td>Subtotal</td> </td></td>	Slight Damage (Storm) <td>Refund of Prior Year Expenditure <td>Subtotal</td> </td>	Refund of Prior Year Expenditure <td>Subtotal</td>	Subtotal
	\$113,902.63	\$405,020.88	\$482,871.98	\$4,292.46	\$16,404.76	\$989,690.48

2015-2016
Beginning Balance (July 1) \$842,659.58

Add: Revenue	Property Taxes	EMC Insurance	MS Water Damage	Slight Damage (Storm)	Refund of Prior Year Expenditure	Subtotal
	\$141,210.84	\$400,360.18	\$480,310.99	\$20,172.15	\$99,594.54	\$1,466,904.06
	Property Taxes <td>EMC Insurance <td>MS Water Damage <td>Slight Damage (Storm) <td>Refund of Prior Year Expenditure <td>Subtotal</td> </td></td></td></td>	EMC Insurance <td>MS Water Damage <td>Slight Damage (Storm) <td>Refund of Prior Year Expenditure <td>Subtotal</td> </td></td></td>	MS Water Damage <td>Slight Damage (Storm) <td>Refund of Prior Year Expenditure <td>Subtotal</td> </td></td>	Slight Damage (Storm) <td>Refund of Prior Year Expenditure <td>Subtotal</td> </td>	Refund of Prior Year Expenditure <td>Subtotal</td>	Subtotal
	\$141,210.84	\$400,360.18	\$480,310.99	\$20,172.15	\$99,594.54	\$1,466,904.06

2016-2017
Beginning Balance (July 1) \$842,659.58

Add: Revenue	Property Taxes	EMC Insurance	MS Water Damage	Slight Damage (Storm)	Refund of Prior Year Expenditure	Subtotal
	\$141,210.84	\$400,360.18	\$480,310.99	\$20,172.15	\$99,594.54	\$1,466,904.06
	Property Taxes <td>EMC Insurance <td>MS Water Damage <td>Slight Damage (Storm) <td>Refund of Prior Year Expenditure <td>Subtotal</td> </td></td></td></td>	EMC Insurance <td>MS Water Damage <td>Slight Damage (Storm) <td>Refund of Prior Year Expenditure <td>Subtotal</td> </td></td></td>	MS Water Damage <td>Slight Damage (Storm) <td>Refund of Prior Year Expenditure <td>Subtotal</td> </td></td>	Slight Damage (Storm) <td>Refund of Prior Year Expenditure <td>Subtotal</td> </td>	Refund of Prior Year Expenditure <td>Subtotal</td>	Subtotal
	\$141,210.84	\$400,360.18	\$480,310.99	\$20,172.15	\$99,594.54	\$1,466,904.06

12

LOCAL OPTION SALES TAX----- ONE CENT SALES TAX--SILO TAX

	2014-2015	2015-2016	2016-2017
Beg Balance (July 1)	\$2,575,056	\$3,318,603	\$3,860,450
Add: Revenue			
1. 1¢ Sales Tax	\$933,380	\$902,761	\$902,347
2. Interest	\$5,541	\$7,147	\$6,916
3. Reim Sterling Comp		\$79,798	
Subtotal	\$3,513,977	\$4,308,309	\$4,769,712
LESS: Expenditures			
1. Computer Lease pymt 3	\$185,722	\$163,691	\$119,135
2. Trebon/Sophos pym2 of 3	\$5,332	\$92,684	\$261,917
3. School Addition Proj. Ahlers	\$1,525	\$11,910	\$163,691
BLDD Contract		\$6,500	\$87,012
4. School Addition Proj. Ahlers	\$1,100	\$3,300	\$136,984
Boyd Jones Contract		\$20,130	\$3,310
5. Transfer to Debt Service	\$1,607	\$12,600	\$20,506
		\$390	\$43,011
Subtotal	\$195,286	\$36,753	\$152,023
TOTAL	\$3,318,691	\$1,835	\$522
Intergov't Receivables	\$171,585	Design Serv-Ltg/Boiler	10. Alley,Poyner, Arch
Sterling Computers	\$79,798	10. Alley Poyner. Arch	11. Boyd Jones-rem. facilities study
BLDD Architects	91875	Prof Services	12. Boyd Jones-Boiler/lighting proj
Final Fund Balance	\$3,318,603	11. Alley Poyner, Arch	13. Bankers Trust-Portion bond pymt
		Prof Services	14. O'Neal Electric(Lighting Proj)
		12. Geotechnical Study	15. Camblin Mechanical(Boiler Proj)
		Thompson,Dressen,Dorner	16. Alley, Pnyer, Arch-copies, conf
		13. Alley Poyner, Arch	17. Camblin Mechanical(Boiler Proj)
		14. Boyd Jones	18. Camblin Mechanical(Boiler Proj)
		15. Impact 7G	19. O'Neal Electric(Lightin Proj)
		16. Impact 7G	20.Credit back from Bond Payment
		17. Alley Poyner, Arch	
		Subtotal	\$1,376,876
		TOTAL	\$3,392,837

ITEMS FOR SALE

Dell-Aruba Access Points (approximately 118)

Nortel Phones—models 1110, 1130, and 1140 (approximately 10-1140; 8-1130, & 150-1110)

Printers—see the list below.

Model	Serial Number	
HP LaserJet 4200n	USGNS51526	
HP LaserJet 600 M603	CNCCF3H075	
Hp Color Lasejet CP4525	JPBCC29137	
HP LaserJet 600 M601	CNBCD6S0FB	
HP LaserJet P4014n	CNDX248702	
HP LaserJet P4014n	CNDX336334	
HP LaserJet 4050N	USBB360776	
HP LaserJet 600 M603	CNCCF4K19R	
HP LaserJet 4250n	CNRXH74496	
Lanier LP137CN	S9319601153	
Ricoh Aficio SP C430DN	S9339601398	
Lanier LP137CN	S9319601149	
Lanier LP137CN	S9329300066	
Lanier LP137CN	S9338900841	
Lanier Aficio SP C430DN	S9339400137	
HP LaserJet P3015	vnb3y60309	
XERON Phaser 6125	LAN037187	
HP LaserJet 4000 N	USEB024260	
Hp Color Lasejet CP4525	JPBCC4014G	
Hp LaserJet 4100n	USLNH19619	
HP LaserJet P4014n	CNDX814031	
HP LaserJet P4014n	CNDX410474	
Hp LaserJet 4100n	USLND15229	
LEXMARK E260dn	72BF1C3	

USED SCHOOL BUS-STILL NEED DETAILS FROM CARLOS

OLD SNAPPER RIDING MOWER-NEED DETAILS FROM ADAM

Tammi VanMeter

From: Carlos Guerra
Sent: Friday, June 2, 2017 1:28 PM
To: Tammi VanMeter
Cc: Tom Messinger
Subject: 2 Buses For Sale

Bus # 3
2001 Thomas International
T444E Engine
65 passenger
Hydraulic brakes

Bus #5
2000 Thomas Freightliner
5.9L Cummins
59 passenger
Air Brakes

If you would like to see the buses or any question please contact Carlos Guerra @ 712-623-6606 or 712-370-6606

CARLOS GUERRA III
RED OAK COMMUNITY SCHOOL DIST.
DIRECTOR OF TRANSPORTATION
2011 N 8TH RED OAK, IA 51566
GUERRAC@ROSCHOOLS.ORG
O 712-623-6606
C 712-370-6606

Dickel Duit Outdoor Power Inc

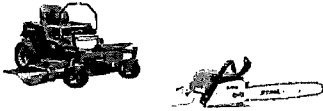

2227 State Hwy 48 / Red Oak IA 51566
 712-623-9343 / Fax: 712-623-4425
 www.dickelduit.com

Printed On : 05/31/2017 9:56:26 AM (Sales Rep ::AJL - Contact ID :11)

Status : **Open**

Invoice #**24790**

Type : **Major Unit Quote** Date : **05/26/2017**

Contact ID :**338**

Customer # : **712-623-6600**

Tax Exempt #**42-6038403**

RED OAK COMMUNITY SCHOOLS

2011 N 8TH ST
 RED OAK, Iowa 51566
 UNITED STATES
 BLAYMO@ROSCHOOLS.ORG
 712-623-6600 - Work
 712-621-3368 Ext.Adam - Mobile

Selected Units for Sale

N/U	Year	Make	Model	Unit Type	VIN/Serial	MSRP	Sale Price	DOC Fees	Off'l Fees	Prot. Pkg
N	N/A	HUSTL	929935	Zero Turn	11100540	\$13,749.00	\$10,036.00	\$0.00	\$0.00	\$0.00
		ER	SUPER Z KW FX 1000 35HP-60 DECK SUSPENTION SEAT							

Disclaimer

Thank you! Your business is always appreciated!
 Hours M-F 8am-6pm Sat 8am-2pm
 Equipment quote prices are good for 30 days from date of quote.
 Visit us at www.dickelduit.com or dickelduit.stihldealer.net

Totals		
Sub Total	+	\$10,036.00
*** Invoice Total	=	\$10,036.00
Amount Paid	-	\$0.00
*** Transaction Total	=	\$10,036.00
Balance Due =		\$10,036.00

Deposit Paid \$0.00

<u>Tax Name</u>	<u>Tax Amount</u>
Exempt	\$0.00

Signature _____

25

Dickel Duit Outdoor Power Inc



2227 State Hwy 48 / Red Oak IA 51566
 712-623-9343 / Fax: 712-623-4425
 www.dickelduit.com

Printed On : 05/31/2017 9:55:15 AM (Sales Rep ::AJL - Contact ID :11)

Status : **Open**

Invoice #**24793**

Type : **Major Unit Quote** Date : **05/26/2017**

Contact ID :**338**

Customer # : **712-623-6600**

Tax Exempt #**42-6038403**

RED OAK COMMUNITY SCHOOLS

2011 N 8TH ST
 RED OAK, Iowa 51566
 UNITED STATES
 BLAYMO@ROSCHOOLS.ORG
 712-623-6600 - Work
 712-621-3368 Ext.Adam - Mobile

Selected Units for Sale

N/U	Year	Make	Model	Unit Type	VIN/Serial	MSRP	Sale Price	DOC Fees	Off'l Fees	Prot. Pkg
N/A	HUSTL	ER	934919	Zero Turn		\$15,182.00	\$11,082.86	\$0.00	\$0.00	\$0.00
			HUSTLER							
			SUPER Z							
			HYPERDRIVE							
			VANGUARD BIG							
			BLOCK (36HP)							
			60IN GRAMMER							
			SUSP SEAT							
			W/ISOLATOR							

Disclaimer

Thank you! Your business is always appreciated!
 Hours M-F 8am-6pm Sat 8am-2pm
 Equipment quote prices are good for 30 days from date of quote.
 Visit us at www.dickelduit.com or dickelduit.stihldealer.net

Totals		
Sub Total	+	\$11,082.86
*** Invoice Total	=	\$11,082.86
Amount Paid	-	\$0.00
*** Transaction Total	=	\$11,082.86
Balance Due =		\$11,082.86

Deposit Paid \$0.00

<u>Tax Name</u>	<u>Tax Amount</u>
Exempt	\$0.00

Signature _____

26

Dickel Duit Outdoor Power Inc



2227 State Hwy 48 / Red Oak IA 51566
 712-623-9343 / Fax: 712-623-4425
 www.dickelduit.com

Printed On : 05/31/2017 9:53:54 AM (Sales Rep ::AJL - Contact ID :11)

Status : **Open** Invoice #**24792**
 Type : **Major Unit Quote** Date : **05/26/2017**

Contact ID : **338**
 Customer # : **712-623-6600**
 Tax Exempt #**42-6038403**

RED OAK COMMUNITY SCHOOLS

2011 N 8TH ST
 RED OAK, Iowa 51566
 UNITED STATES
 BLAYMO@ROSCHOOLS.ORG
 712-623-6600 - Work
 712-621-3368 Ext.Adam - Mobile

Selected Units for Sale

N/U	Year	Make	Model	Unit Type	VIN/Serial	MSRP	Sale Price	DOC Fees	Off'l Fees	Prot. Pkg
N/A		HUSTL	935007	Zero Turn		\$13,127.00	\$9,582.71	\$0.00	\$0.00	\$0.00
		ER	HUSTLER SUPER Z KAWASAKI FX850 (27HP) 60IN GRAMMER SUSPENSION SEAT							

Disclaimer

Thank you! Your business is always appreciated!
 Hours M-F 8am-6pm Sat 8am-2pm
 Equipment quote prices are good for 30 days from date of quote.
 Visit us at www.dickelduit.com or dickelduit.stihldealer.net



Totals		
Sub Total	+	\$9,582.71
*** Invoice Total	=	\$9,582.71
Amount Paid	-	\$0.00
*** Transaction Total	=	\$9,582.71
Balance Due =		\$9,582.71

Deposit Paid \$0.00

Tax Name Exempt Tax Amount \$0.00

Signature _____

27

Dickel Duit Outdoor Power Inc



2227 State Hwy 48 / Red Oak IA 51566
 712-623-9343 / Fax: 712-623-4425
 www.dickelduit.com

Printed On : 05/31/2017 9:57:31 AM (Sales Rep ::AJL - Contact ID :11)

Status : **Open**

Invoice #**24791**

Type : **Major Unit Quote** Date : **05/26/2017**

Contact ID :**338**

Customer # : **712-623-6600**

Tax Exempt #**42-6038403**

RED OAK COMMUNITY SCHOOLS

2011 N 8TH ST
 RED OAK, Iowa 51566
 UNITED STATES
 BLAYMO@ROSCHOOLS.ORG
 712-623-6600 - Work
 712-621-3368 Ext.Adam - Mobile

Selected Units for Sale

N/U	Year	Make	Model	Unit Type	VIN/Serial	MSRP	Sale Price	DOC Fees	Off'l Fees	Prot. Pkg
N	N/A	HUSTL	927889B	Zero Turn	10090421	\$11,549.00	\$8,430.77	\$0.00	\$0.00	\$0.00
		ER	SUPER Z 25HP KAWASAKI 60 DECK XR-7 SUSP SEAT							

Disclaimer

Thank you! Your business is always appreciated!
 Hours M-F 8am-6pm Sat 8am-2pm
 Equipment quote prices are good for 30 days from date of quote.
 Visit us at www.dickelduit.com or dickelduit.stihldealer.net

Totals		
Sub Total	+	\$8,430.77
*** Invoice Total	=	\$8,430.77
Amount Paid	-	\$0.00
*** Transaction Total	=	\$8,430.77
Balance Due =		\$8,430.77

Deposit Paid \$0.00

<u>Tax Name</u>	<u>Tax Amount</u>
Exempt	\$0.00

Signature _____

28



JOHN DEERE

Selling Equipment

Quote Id: 15425859

Customer: RED OAK CMNTY SCHL DST FNDTION

JOHN DEERE Z950M Commercial Ztrak				
Hours:				Suggested List
Stock Number:				\$ 12,852.99
				Selling Price
				\$ 9,406.03
				Extended
				\$ 10,999.00
Code	Description	Qty	Unit	
0691TC	Z950M Commercial Ztrak	1	\$ 10,999.00	
Standard Options - Per Unit				
001A	United States/Canada	1	\$ 0.00	\$ 0.00
1036	24x12x12 Pneumatic Turf Tire for 54 In. and 60 In. Decks	1	\$ 0.00	\$ 0.00
1505	60 In. Mulch On Demand Mower Deck	1	\$ 870.00	\$ 870.00
2002	Fully Adjustable Suspension Seat with Armrests	1	\$ 475.00	\$ 475.00
Standard Options Total				\$ 1,345.00
Value Added Services Total				\$ 0.00
Other Charges				
	Freight	1	\$ 468.99	\$ 468.99
	EnviroCrate	1	\$ 40.00	\$ 40.00
Other Charges Total				\$ 508.99
Suggested Price				\$ 12,852.99
Customer Discounts				
Customer Discounts Total			\$ -3,446.96	\$ -3,446.96
Total Selling Price				\$ 9,406.03

29

AIA[®] Document G701/CMa[™] – 1992

Change Order - Construction Manager-Adviser Edition

PROJECT (Name and address):
 ROCSD Accessibility Update
 Red Oak Community School District
 Red Oak, IA 51566

CHANGE ORDER NUMBER: 003
INITIATION DATE: 04/03/2017

OWNER:
 CONSTRUCTION MANAGER:
 ARCHITECT:
 CONTRACTOR:
 FIELD:
 OTHER:

TO CONTRACTOR (Name and address):
 McKee Contracting Co.
 1740 A Avenue
 Emerson, IA 51533

PROJECT NUMBERS: /
CONTRACT DATE: October 12, 2016
CONTRACT FOR: General
 Construction

THE CONTRACT IS CHANGED AS FOLLOWS:

Changes per RFI #4 - Middle School Locker Mounting
 - Blocking behind lockers. \$280.00
 - Fold-up shower seat. \$464.00
 Total \$744.00

The original Contract Sum was	\$ 53,000.00
Net change by previously authorized Change Orders	\$ 15,884.78
The Contract Sum prior to this Change Order was	\$ 68,884.78
The Contract Sum will be increased by this Change Order in the amount of	\$ 744.00
The new Contract Sum including this Change Order will be	\$ 69,628.78

The Contract Time will be increased by Zero (0) days.
 The date of Substantial Completion as of the date of this Change Order therefore is unchanged.

NOTE: This summary does not reflect changes in the Contract Sum, Contract Time or Guaranteed Maximum Price which have been authorized by Construction Change Directive..

NOT VALID UNTIL SIGNED BY THE OWNER, CONSTRUCTION MANAGER, ARCHITECT AND CONTRACTOR.

Boyd Jones Construction Company
CONSTRUCTION MANAGER (Firm name)
 4360 Nicholas Street, Omaha, NE 68131
ADDRESS

Alley Poyner Macchietto Architecture, Inc.
ARCHITECT (Firm name)
 302 Coolbaugh Street, Red Oak, IA 51566
ADDRESS

BY (Signature)
 Dick Streff
 (Typed name) DATE: 4/4/17

BY (Signature)
 Daric O'Neal
 (Typed name) DATE: 4/12/17

McKee Contracting Co.
CONTRACTOR (Firm name)
 31740 A Avenue, Emerson, IA 51533
ADDRESS

Red Oak Community School District
OWNER (Firm name)
 2011 North 8th Street, Red Oak, IA 51566
ADDRESS

BY (Signature)
 Wade McKee
 (Typed name) DATE:

BY (Signature)
 Paul Griffen, President, Board of Directors
 (Typed name) DATE:

1
30

McKee Contracting Co.

March 02, 2017

Boyd Jones
4360 Nicholas Street
Omaha, NE. 68131
402.553.1804

**RE: Red Oak CSD – Accessibility Update
Locker blocking**

The following quote is to provide blocking behind the lockers at the middle school to accommodate the conduit mounted on the wall. Price includes wood blocking around the perimeter of the lockers and painted to match the wall color.

Total labor, materials, and clean up..... \$ 280.00

Thank you,

Wade McKee

31

McKee Contracting Co.

April 3, 2017

Boyd Jones
4360 Nicholas Street
Omaha, NE. 68131
402.553.1804

**RE: Red Oak CSD – Accessibility Update
High School ADA shower seat**

The following quote is to supply ASI Model 8202 L shaped fold up shower seat.

EPCO \$ 422.00

Mark up..... 42.00

TOTAL..... \$ 464.00

Thank you,

Wade McKee

32



AMERICAN SPECIALTIES, INC.
 441 Saw Mill River Road, NY 10701
 (914) 476.9000 • (914) 476.0688
 www.americanspecialties.com

MODEL №: 8202

ISSUED: 09/09

REVISED: 02/11

L-SHAPED PHENOLIC FOUR-LEG FOLD-UP SHOWER SEAT (1/2)

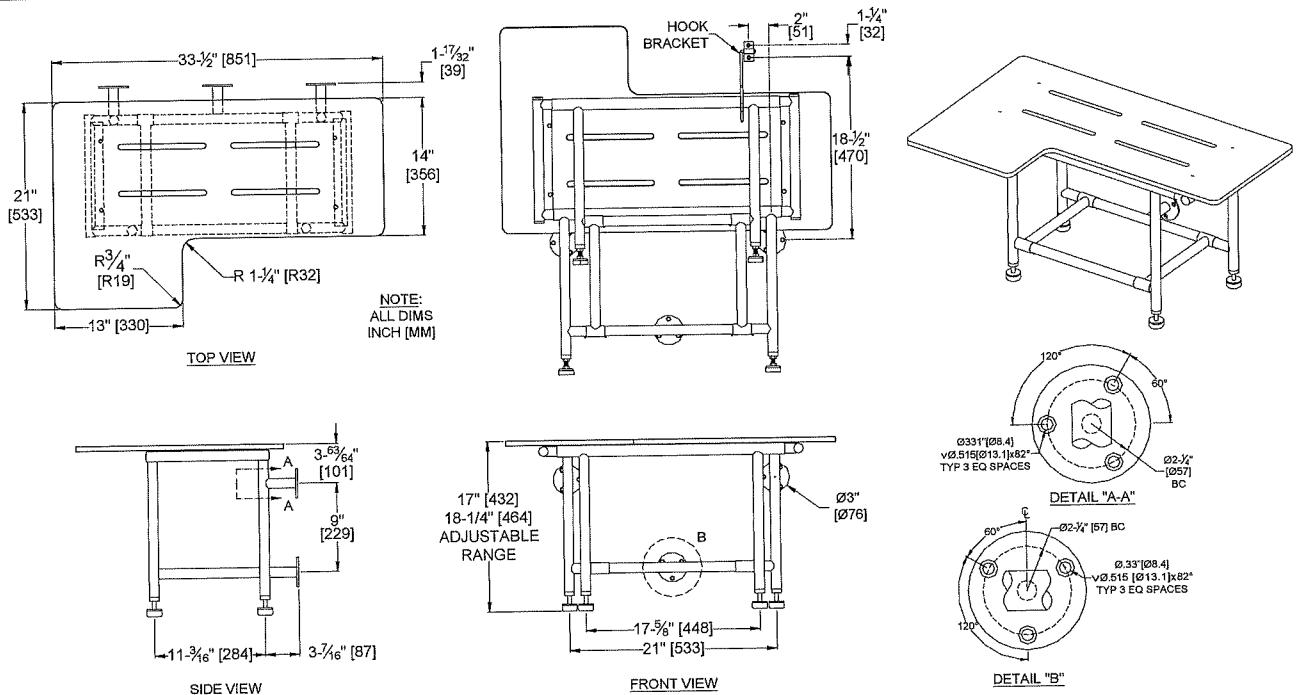

SPECIFICATION

L-shaped Phenolic Four-Leg Fold-up Shower Seat shall have all metal parts fabricated of type 304 stainless steel 18-8 alloy. Seat frame and support legs shall be 1-1/8" diameter (Ø29) x 16 gauge and 1" diameter (Ø 25) x 14 gauge and pivoting sleeves shall be 1-1/8" diameter (Ø29) x 20 gauge with 3/16" (4.8) thick mounting flanges and 12 gauge seat mounting brackets. All exposed surfaces shall have satin finish. Structural assembly shall be of welded construction and all exposed edges and corners shall be radiused and/or deburred. Seat shall be solid phenolic with white top and bottom surfaces and shall have black edges. Legs shall fold up when in retracted position to provide low profile against wall. Stainless steel hook bracket shall be provided to retain seat in storage position. Rubber cushioned stainless steel leveling feet shall lock-adjust throughout installation height range and compensate for uneven floors. Unit shall satisfy ADA Accessibility Guidelines when mounted properly.

L-shaped Phenolic Four-Leg Fold-up Shower Seat shall be Model № 8202 - __ (R for right hand or L for left hand) of American Specialties, Inc., 441 Saw Mill River Road, Yonkers, New York 10701- 4913

INSTALLATION

This unit is surface mounted. Installer/construction contractor must provide concealed anchor plate or blocking as specified in construction documents or as required by local building codes prior to wall finishing. Fasten unit flanges and retaining hook bracket to concealed anchors or blocking plates with appropriate hardware (by others). See "STRENGTH" section below. Note that concealed mounting plates or anchors and hardware are not supplied with this product and must be specified separately. Ensure that mounting configuration complies with local building codes. Adjust leveling feet to provide even load transfer to floor and lock with nuts (provided) to maintain position. Unit is reversible in the field for right or left hand installation.

Accessory Specialties

AMERICAN DISPENSER

Desert Ray Products

WATROUS INC.

THIS MANUFACTURER RESERVES THE RIGHT TO MAKE CHANGES IN DESIGN OR DIMENSIONS WITHOUT FORMAL NOTICE

33



AMERICAN SPECIALTIES, INC.
441 Saw Mill River Road, NY 10701
(914) 476.9000 • (914) 476.0688
www.americanspecialties.com

MODEL No: 8202

ISSUED: 09/09

REVISED: 02/11

L-SHAPED PHENOLIC FOUR-LEG FOLD-UP SHOWER SEAT (2/2)

STRENGTH

ASI Shower Seats are designed to meet and exceed **ADAAG** requirements as published in ICC/ANSI A117.1-2003 section 610 and CFR 28 Part 36, Federal Register Vol. 56 N^o 144, 26 July 1991, section 4.21.3 and section 4.26.3, that fabricated product shall be of adequate strength to support a load of 250 pounds (113.4 kg) and unit shall conform to size and edge clearances as diagrammed. Mounting to the wall is a critical part of the system to meet this requirement. To withstand the shear, tension or pullout, and torsion loads generated by the maximum loading, the fastener system must be adequately sized. Unit is load rated to support a weight of 1000 lbs (454 kg) when properly installed and has been tested to successfully hold a weight in excess of 1,250 lbs (567 kg).

MATERIALS

Tubes: 14 gauge (.075" <1.9> thick) 1" diameter (Ø25) and 16 gauge (.06" <1.5> thick) & 20 gauge (.04" <1.0> thick) 1-1/8" diameter (Ø29), all type 304 stainless steel. Unitized all welded construction. Exposed surfaces have satin finish. Edges and corners are radiused and burr free. Frame is field reversible for either left or right hand.

Flanges: 3/16" (4.8), type 304 stainless steel. Exposed surfaces have satin finish. Edges are radiused and burr free.

Brackets: 12 gauge (.106" <2.7> thick), type 304 stainless steel. Exposed surfaces have satin finish. Edges are radiused and burr free.

Seat: Solid Phenolic (L-shape) 1/2" x 33-1/2" x 21" (13 x 851 x 533) nonporous seat has white top and bottom surfaces with semi-gloss finish and black edges with radiused and burr free corners. Seat shall be field reversible for left or right hand. Seat shall have slots for water drainage and user slip resistance. Mounting hardware is smooth stainless steel dome head carriage bolts with acorn nuts on bottom.

Retainer: 1/4" diameter (Ø6.4) rod, 3/16" thick (4.8) mounting plate, 1/2" diameter (Ø13) pivot all type 304 stainless steel. Exposed surfaces have satin finish. Edges are radiused and burr free.

OPERATION

Fold-up Shower Seat requires only one hand operation to manually lower to horizontal position for use or raise for departure and arrival. Rear load feet remain on floor with rear frame mounted to wall and never need adjustment after correct installation. Front legs fold up automatically when seat is raised. Retainer hook prevents seat from dropping. Rubber cushions on load leveling feet prevent shocks to floor surface during deployment and use. Unit may be hosed for cleaning at same time as shower enclosure.

Woodward-Granger Community School District

Serving the Communities of Woodward and Granger

Bradley Anderson
Superintendent
1904 State St.
Granger, IA 50109
515-999-8022
Fax 515-999-8025

Robb Boley
HS Principal
306 West Third St.
Woodward, IA 50276
515-438-2115
Fax 515-438-4329

Bret Miller
MS Principal
306 West Third Street
Woodward, IA 50276
515-438-4263
Fax 515-438-4329

Matt Brummond
Early Learning Ctr. Principal
2200 State Street
Granger, IA 50109
515-999-8058
Fax 515-999-8060

Matt Brummond
Elementary Principal
2002 Oak St.
Granger, IA 50109
515-999-2357
Fax 515-999-9299

Rebekka Maass
Grandwood Principal
1251 334th Street
Woodward, IA 50276
515-438-3240
Fax 515-438-3414

Building Futures, One Student at a Time

INTER-AGENCY AGREEMENT FOR SPECIAL EDUCATION

INSTRUCTIONAL PROGRAM 2016-2017

This agreement is entered in Red Oak CSD and the WOODWARD-GRANGER COMMUNITY SCHOOL DISTRICT.

We, the undersigned agencies, for each special education student being provided services or programs by other than the student's agency of residence, do hereby consent and agree to the following conditions:

CONDITION I

The receiving agency shall provide instructional services and programs for the students referred for special education classes in accordance with the State of Iowa Department of Education Rules and Regulations and in accordance with the state laws governing such services and the delivery thereof (Chapters 273, 281 and 442). The receiving agency shall retain the right to limit enrollment.

CONDITION II

The cost of the above services shall be paid by the sending agency to the receiving agency and shall be actual costs incurred in providing these services and programs. Payment of these actual costs will be determined in the following manner:

- A. The receiving agency shall provide the sending agency with SEMI-ANNUAL INVOICES for the actual costs of services and programs of the current school year. The first invoice will include an estimate of the costs and the final invoice will include the actual costs for the entire year including administrative costs minus previously paid amounts. Cost will be prorated to the days of service if the service is for less than one year.
- B. For Special education services provided by the Woodward Youth Academy, located within the Woodward-Granger School District, tuition invoices shall be forwarded to the sending agency when Woodward Academy makes costs known to the W-G Business Office.
- C. The receiving district shall provide the sending agency with an itemized final statement of the actual costs of services and itemize any payments received toward the cost.

Signed _____
Superintendent or Authorized Agent Designee of Sending District

Date _____

Signed 
Superintendent or Authorized Agent Designee, W-G Community School

Date: 6/20/17

Contract Services provided for:

Academy Special Education Program

Return one signed copy to:

Woodward-Granger Schools, 1904 State Street, Granger, IA 50109
Attention: Beth Griffin

35

June 12, 2017

RECEIVED
JUN 12 2017
BY: *JS*

Dear Mr. Spotts,

Effective June 30, 2017, I will be resigning my position as a member of the Teacher Leadership team at Red Oak High School.

Sincerely,



Alan D. Spencer
Agricultural Education Instructor/FFA Advisor
Red Oak High School
2011 North 8th Street
Red Oak, IA 51566
712-623-6610

RECEIVED
JUN 13 2017
BY: _____ *N*

L. Brian Orr
Red Oak, IA 51566

Mr. Tom Messinger
Superintendent
Red Oak Community School District
Administrative Center
2011 N 8th Street, Tech Bldg.
Red Oak, IA 51566

13 June, 2017

Dear Mr. Messinger,

Please accept my resignation from my position as the K-5 Student Support Coordinator for the Red Oak Community School District.

The students, parents, faculty, and staff have given me immense pleasure to work with, and to work for. The administration has been supportive during my short tenure with the school district, and I wish everyone the best.

If I can be of any assistance, to you or the K-5 faculty and staff during the remainder of the summer break, please let me know.

Respectfully,



L. B. Orr

cc: Mrs. Barb Sims, Principal, Washington Intermediate School
Mrs. Gayle Allensworth, Principal, Inman Primary School

RECEIVED
MAY 18 2017
BY: _____ JW

To Whom it May Concern,

I am writing this letter in regards to my current position as the 7th grade volleyball coach in the Red Oak School District. I am asking for a one-year leave of absence from my position, returning back in August of 2018. I am making this request due to my extensive schooling. I will be taking part in full-time classes and clinical in the fall, which does not allow adequate time to coach.

Thank you in advance for your consideration and for your time.

Sincerely,

McKaela Magneson

Red Oak Community School District
Staff Selection Recommendation

RECEIVED
JUN 20 2017
BY: JW

Date: 6-20-17

Building: Admin HS MS WIS IPS ECC Trans
(Please Circle All That Apply)

Position: Bus Driver / Transportation

Name: Jerry Wallace

Certified:

Lane: _____

Step: _____

Salary: _____

Classified:

Hourly Rate: 10.45

Hours Per Day: _____

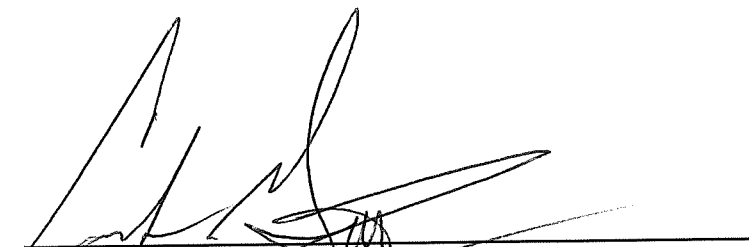

Principal/Director

Please send form to Superintendent for Board Approval

Red Oak Community School District
Staff Selection Recommendation

Date: June 23, 2017

Building: Admin HS MS WIS IPS ECC Trans
(Please Circle All That Apply)

Position: 3rd Grade Teacher

Name: Toni Dolch

Certified:

Lane: BA-~~0~~

Step: 1

Salary: 33,895

Classified:

Hourly Rate: _____

Hours Per Day: _____

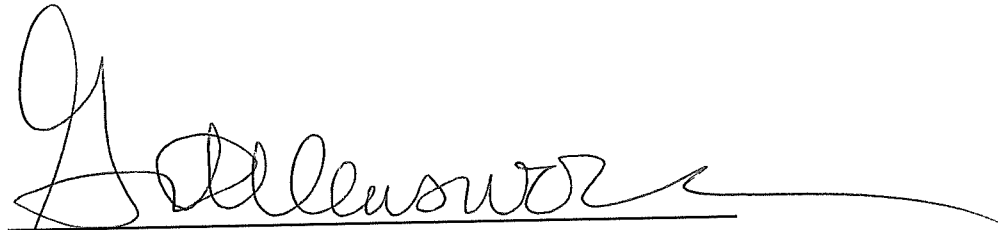
Principal/Director

Please send form to Superintendent for Board Approval

Office Use Only

Background Check: _____